



OLIVIA 4851

(DE) Aufbau- und Gebrauchsanleitung für Art.-Nr. 4851

Für späteres Nachschlagen aufbewahren.

(GB) Instructions for assembly and use for Art. No. 4851

Please keep for further reference.

(FR) Instructions de montage et d'emploi pour article n° 4851

A conserver pour une consultation ultérieure.

(NL) Montage- en gebruiksaanwijzing voor art. nr. 4851

Bewaar voor latere raadpleging.

(IT) Istruzioni di montaggio e uso per l'art. n°. 4851

Conservate questa descrizione per poter far riferimento ad essa in un secondo momento.

(DK) Installations- og brugsanvisning for art.-nr. 4851

Monteringen bør foretages i ro og fred.

(ES) Instrucciones de uso y de montaje para Art. -Núm. 4851

Guárdelas para poder leerlas posteriormente en caso necesario.

(HU) Összeszerelési és használati útmutató következő cikkszámhoz: 4851

Jövőbeni tájékoztatóhoz kérjük, a leírást őrizze meg.

(FI) Asennus- ja käyttöohje, art. nro 4851

Säilytä ohje myöhempää tarvetta varten.

(SI) Navodila za montažo in uporabo za artikel-št. 4851

Navodilo shranite za kasnejšo kontrolo.

(HR) Upute za sastavljanje i uporabu artikla broj 4851

Sačuvajte ih za buduću primjenu.

(NO) Monterings- og bruksveiledning for art. nr. 4851

Oppbevar den for senere bruk.



OLIVIA 4851

Ⓟ Instrukcja montażu i obsługi do nr art. 4851

Zachować instrukcję do późniejszego wykorzystania.

Ⓒ Návod na sestavení a používání pro výr. č. 4851

Uchovejte jej k pozdějšímu nahlédnutí.

Ⓟ Instruções de montagem e uso para o art. nº 4851

Guarde-as para poder consultá-las posteriormente.

Ⓡ Ürün No. 4851 için kurma ve kullanım talimatı

Sonradan okumak için saklayınız.

Ⓢ Návod na montáž a použitie k prod. č.: 4851

Tento návod si uschovajte pre neskoršie použitie.

Ⓤ Uppbyggnads- och bruksanvisning för art.nr. 4851

Spara för att kunna läsa igen längre fram.

Ⓡ Sputstvo za sastavljanje i primenu art. br. 4851

Sačuvati za kasniju upotrebu.

Ⓝ 組み立て・使用説明書 品番 4851

この説明書を大切に保管してください。

Ⓒ 安装与使用说明 - 型号 4851

请妥善保存说明书以备今后查阅。

Ⓡ 제품-No. 의 조립 및 사용 설명 4851

나중에 참조할 수 있도록 설명을 보관하십시오.

Teileliste

List of parts as illustrated

Liste de pièces comme

illustrée Onderdelenlijst

Listino pezzi

Indhold

Lista de piezas

Alkotóelemek jegyzéke

Osaluettelo

Seznam elementov

Popis dijelova

Delliste

Wykaz części

Seznam součástí

Lista de peças

Parça listesi

Zoznam súčiastok

Artikellista









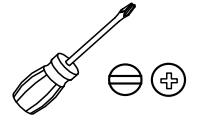

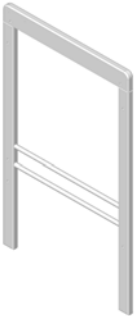

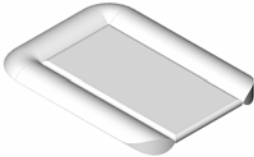
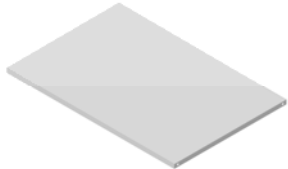
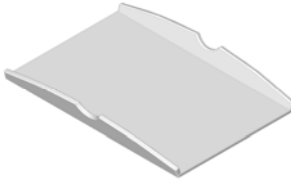







Spisak delova

パーツリスト

零部表

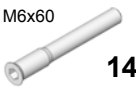
부품 목록

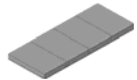

 <p>Rahmen links left frame paroi gauche frame links Sponda sinistra venstre ramme bastidor izquierdo Bal keret</p> <p>1 x</p> <p>Art. Nr. Z072300054</p>	 <p>Rahmen rechts right frame paroi droite frame rechts Sponda destra højre ramme bastidor derecho Jobb keret</p> <p>1 x</p> <p>Art. Nr. Z072300053</p>	 <p>1 x</p> <p>Art. Nr. 205010580</p>		
 <p>1 x</p> <p>Art. Nr. 205910027</p>	 <p>1 x</p> <p>Art. Nr. X071100032</p>	 <p>1 x</p> <p>Art. Nr. Z072300055</p>		
 <p>3 x</p> <p>Art. Nr. Y072300024</p>	 <p>2 x</p> <p>Art. Nr. Y072300025</p>	 <p>1 x</p> <p>Art. Nr. 205010587</p>		
 <p>1 x</p> <p>Art. Nr. 205010588</p>	 <p>1 x</p> <p>Art. Nr. 205010590</p>	 <p>1 x</p> <p>Art. Nr. 205010589</p>	 <p>1 x</p> <p>Art. Nr. 205010586</p>	
 <p>1 x Art. Nr.205010591</p>	 <p>2 x Art. Nr. 205280010 2 x Art. Nr. 205280009</p>			
 <p>Ø4x35 5 x</p> <p>Art. Nr. 204820001</p>	 <p>Ø4x27 4 x</p> <p>Art. Nr. 204820018</p>	 <p>9 x</p> <p>Art. Nr. 204610001</p>	 <p>4 x</p> <p>Art. Nr. 205010542</p>	 <p>M6x60 14 x</p> <p>Art. Nr. 204840022</p>
 <p>14 x</p> <p>Art. Nr. 204500055</p>	 <p>1 x</p> <p>Art. Nr. 205380003</p>	 <p>1 x</p>		

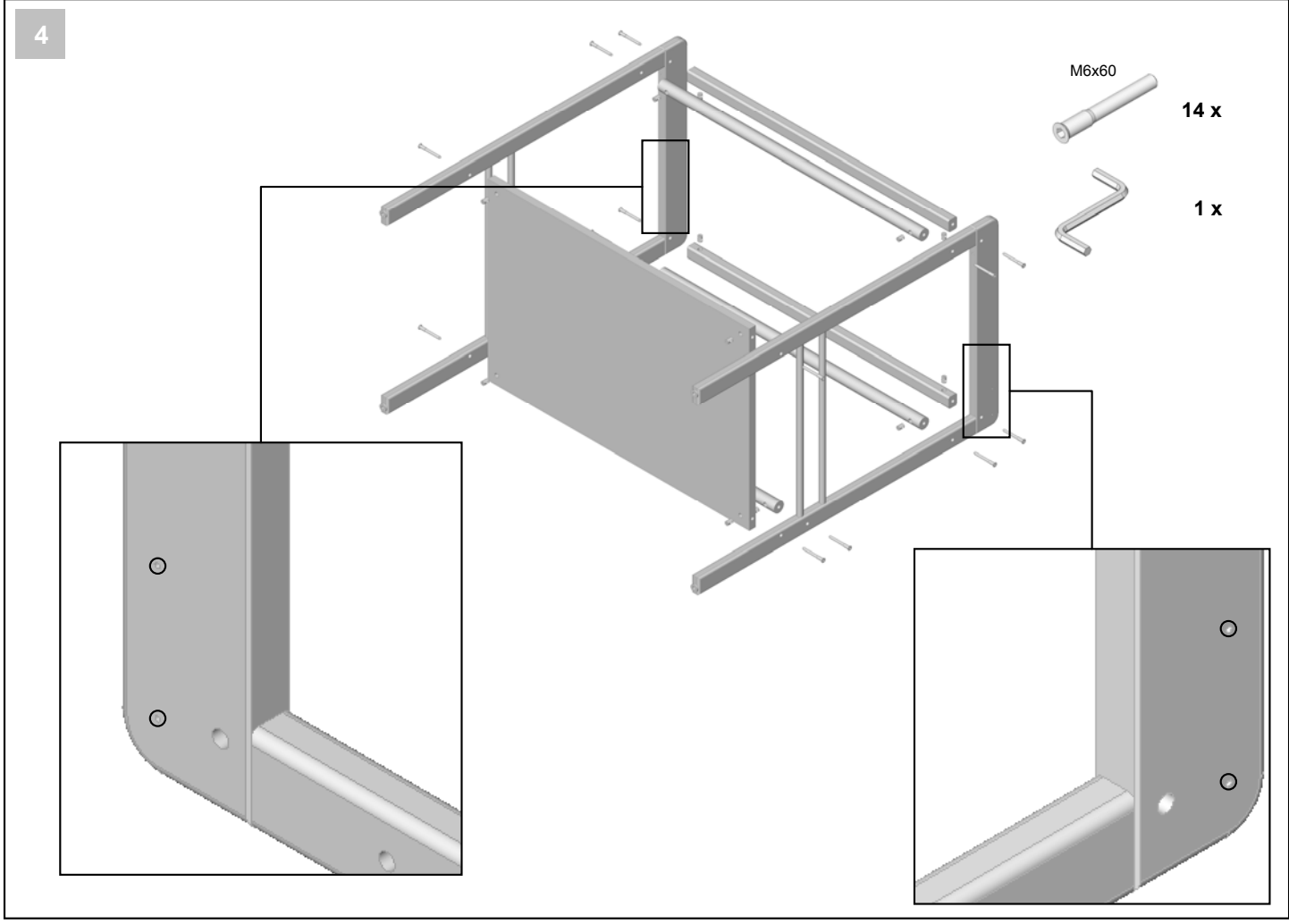
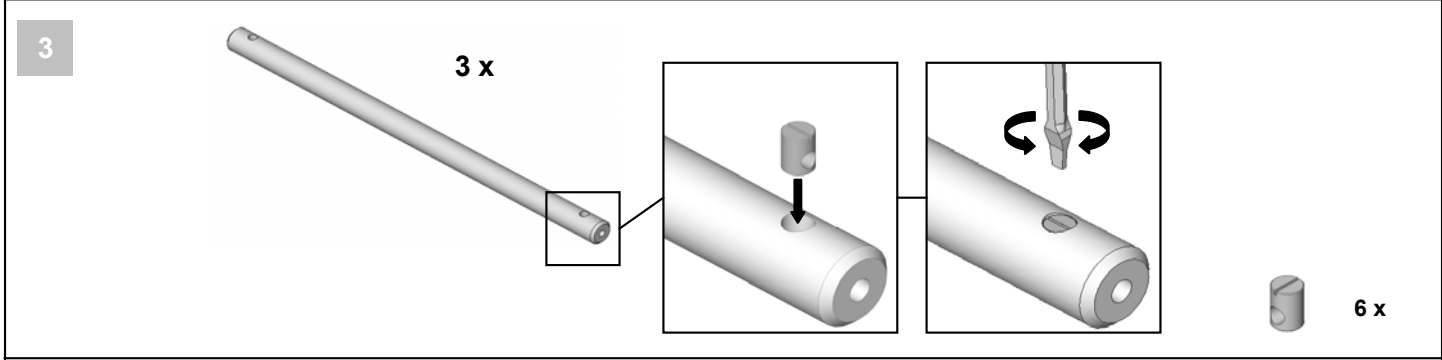
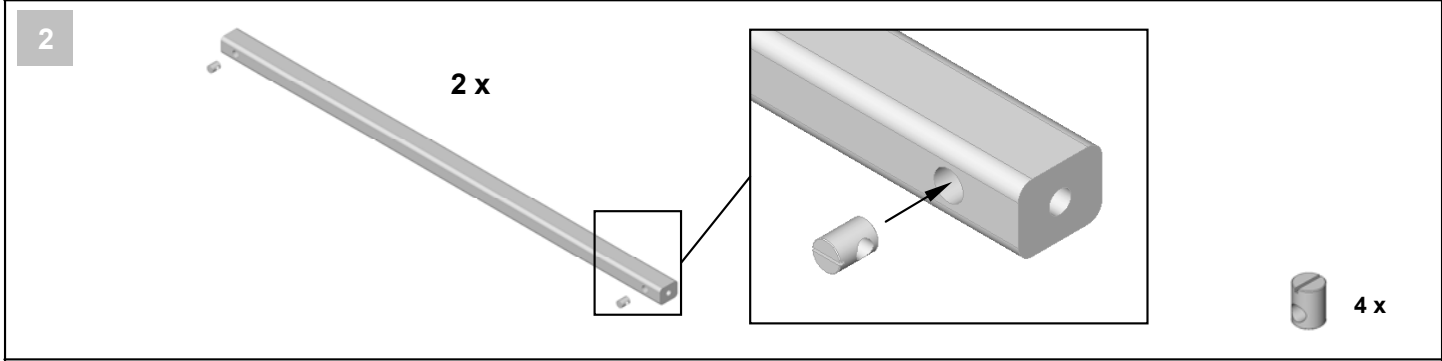
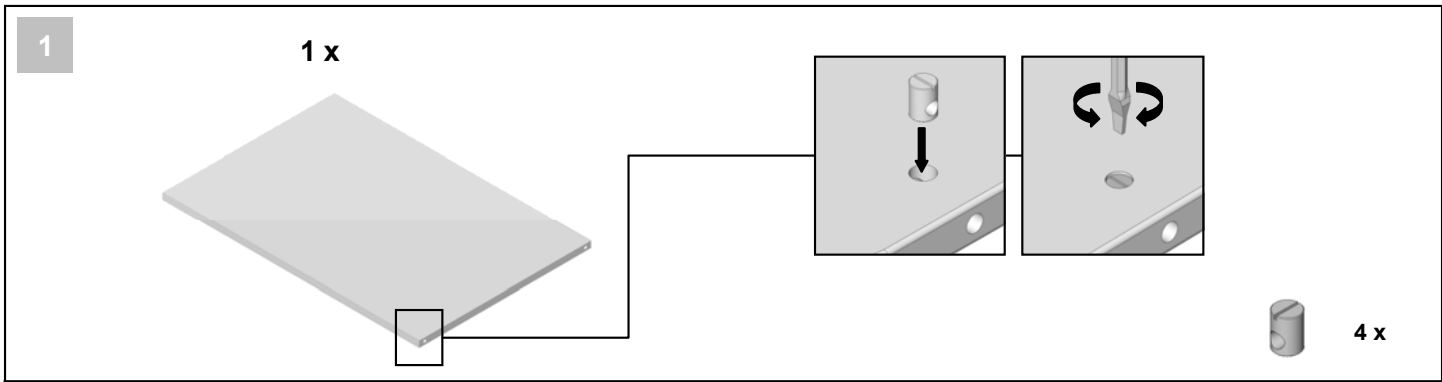

5

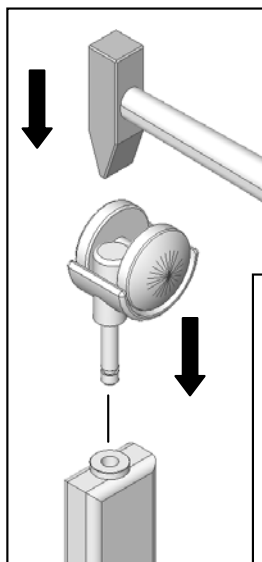
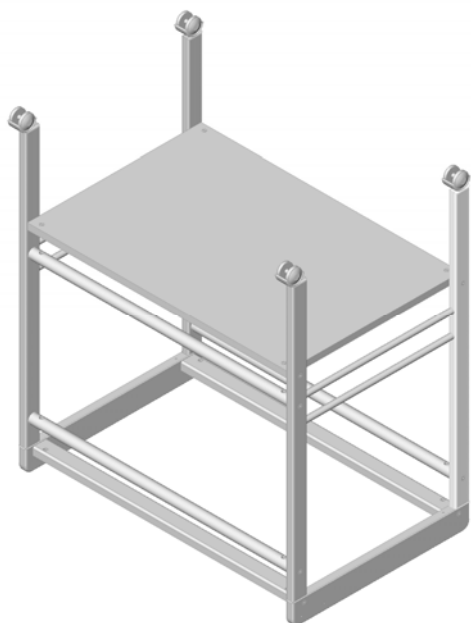

4 x

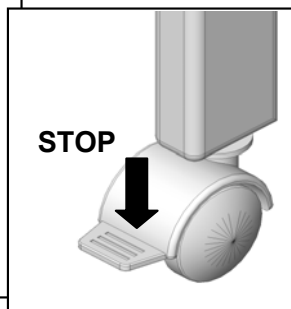

6

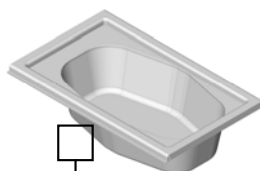

1x

1x

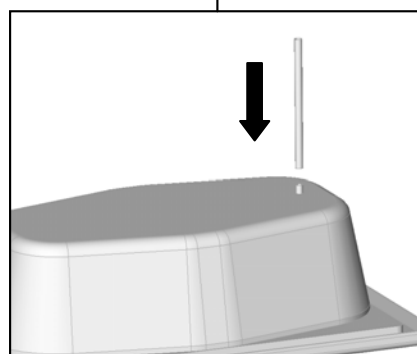

7

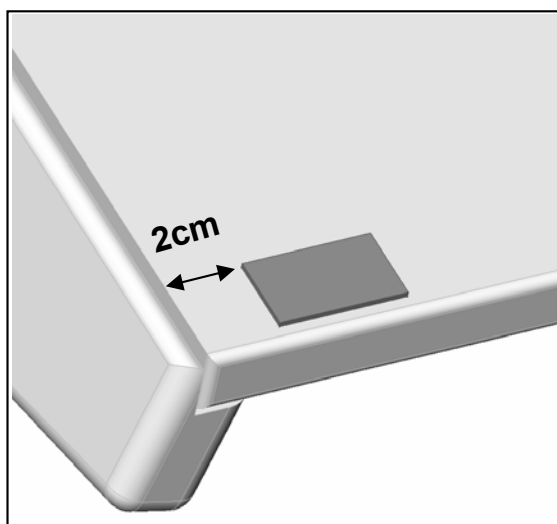

2cm

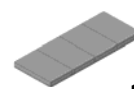
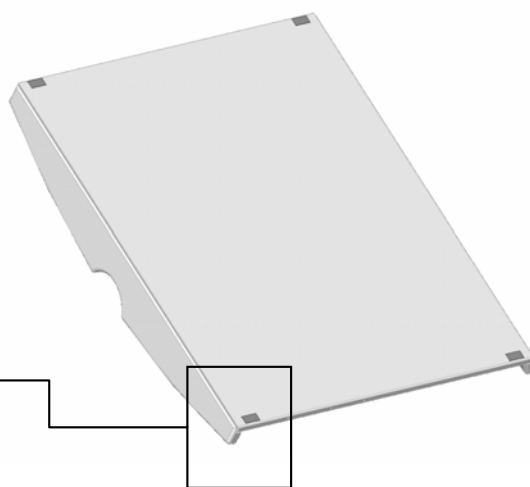

1x



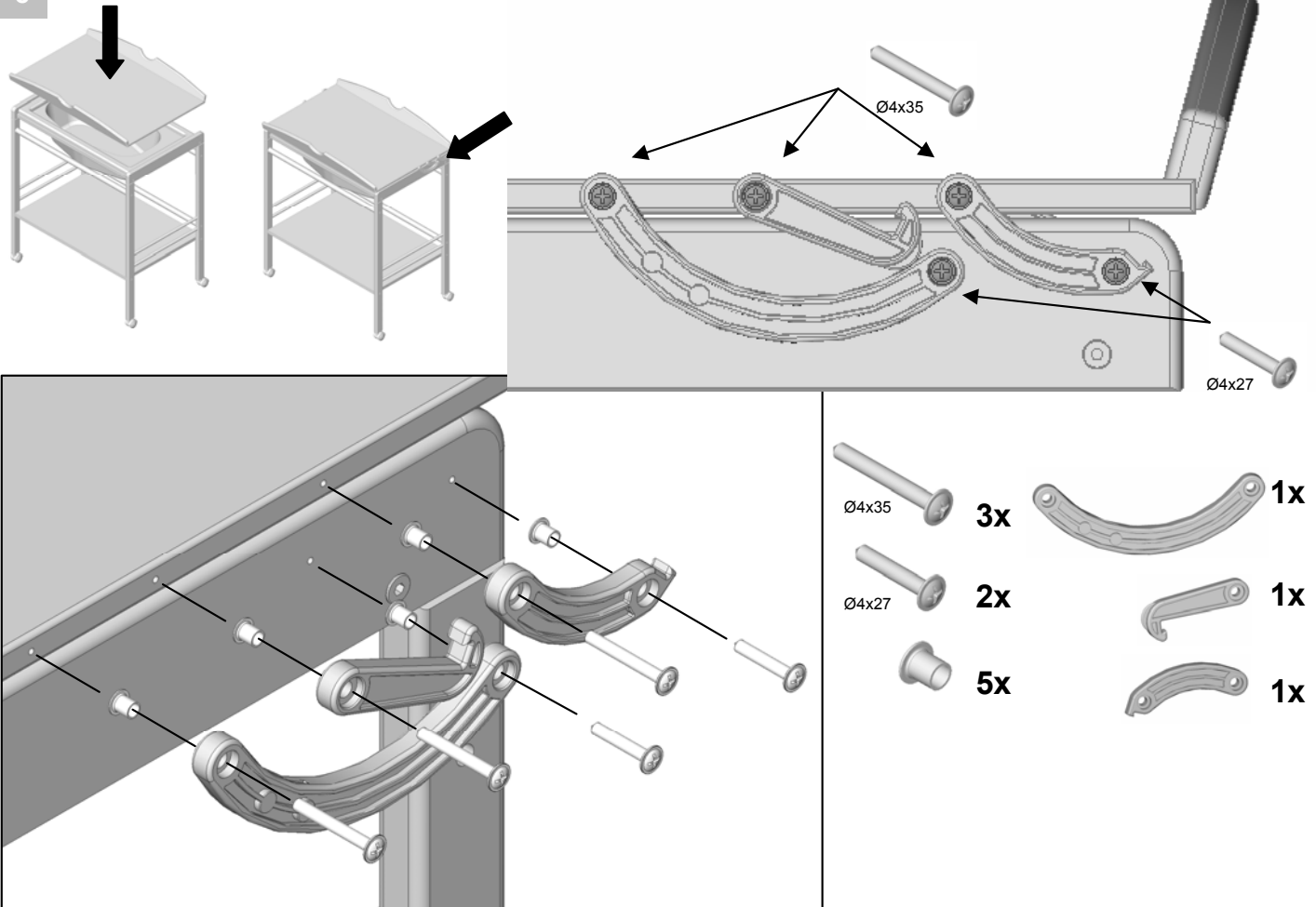

8

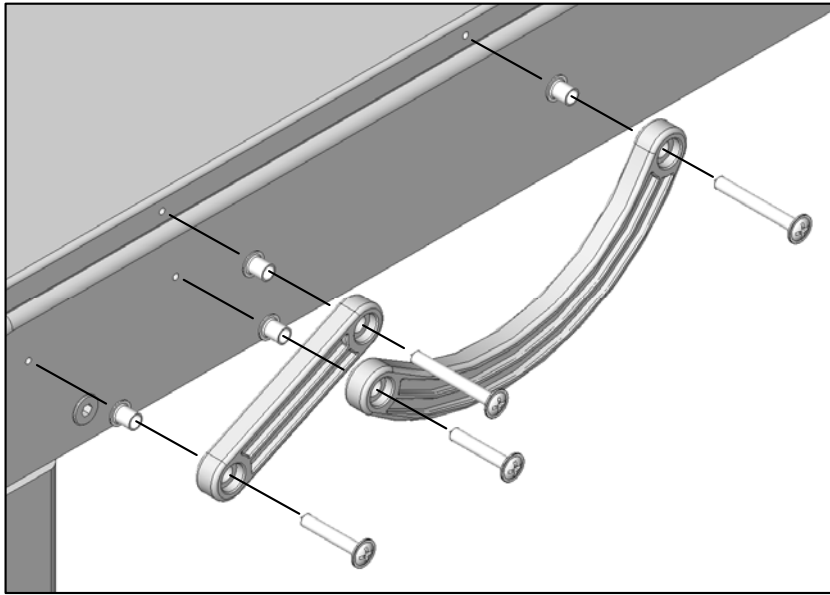

- (DE) Achtung! Alle Schrauben erst lose, dann fest andrehen !
- (GB) Attention! Fasten all screws in a loose position first and tighten them afterwards!
- (FR) Attention! Serrez d'abord légèrement toutes les vis, puis serrez-les à fond!
- (NL) Opgepast! Alle schroeven eerst zacht en dan stevig vastdraaien!
- (IT) Attenzione! Dapprima avvitare tutte le viti e non stringerle, stringerle poi in un secondo momento!
- (DK) Vigtigt! Alle skruerne skrues først løst i og derefter fast!
- (ES) Atención! Al colocar los tornillos, fíjelos ligeramente y después atorníllelos con fuerza!
- (HU) Figyelem! Minden csavart eloször lazán, majd szorosán meghúznak!
- (FI) Huomio! Kierrä kaikki ruuvit ensin löysästi ja kiristä ne sitten!
- (SI) Pozor! Vse vijake najprej narahlo, šele nato trdno priviti !
- (HR) Pozor! Vijke stegnite najprije rukom, a zatim alatom!
- (NO) Obs ! Alle skruene skrues først løst på, deretter skrues de fast!
- (PL) Uwaga! Wszystkie śruby najpierw poluzować, a następnie dokręcić na stałe!
- (CZ) Pozor! Všechny šrouby dotáhnout nejprve lehce, potom pevně!
- (PT) Atenção! Primeiro aperte os parafusos levemente e a seguir, aperte-os bem !
- (TR) Dikkat ! Bütün vidaları ince gevşek daha sonra sıkı sıkınız !
- (SK) Pozor! Všetky skrutky najprv voľno, potom pevne upevnite!
- (SE) Observera! Dra först fast alla skruvar löst, och sedan ordentligt !
- (RS) Pažnja! Sve zavrtnje treba najpre samo ovlaš naviti pa onda dobro pritegnuti!
- (JP) 注意！まず、すべてのネジを緩めてから、改めて固く締めなおしてください！
- (CN) 注意！先松开所有螺栓，然后再紧固！
- (KR) 주의! 먼저 모든 나사를 느슨하게 조이고 그런 다음 단단히 조이십시오!

9

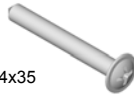

-  1x
-  1x
-  Ø4x35 2x
-  Ø4x27 2x
-  4x

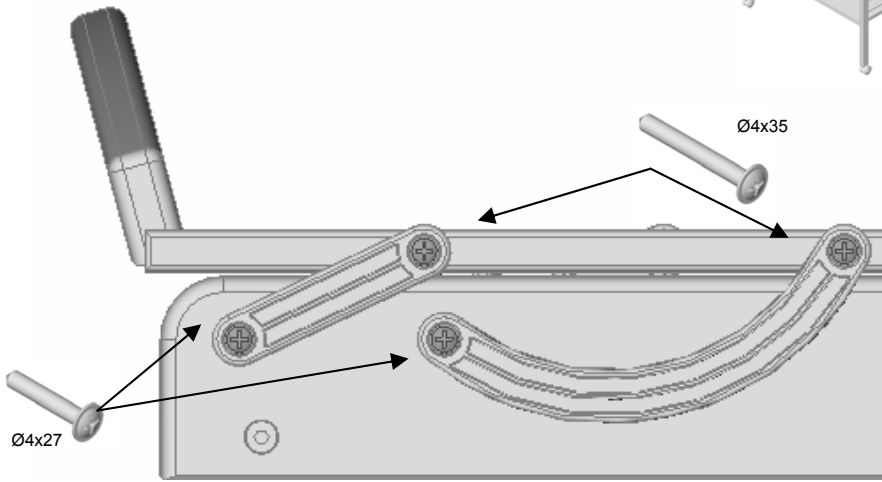

10

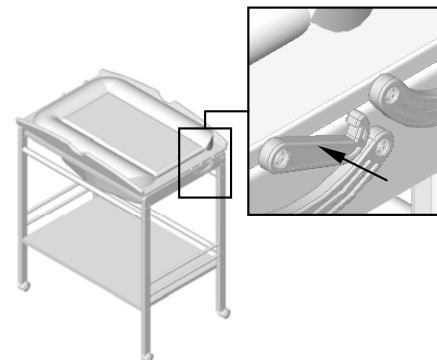
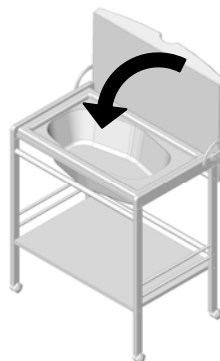
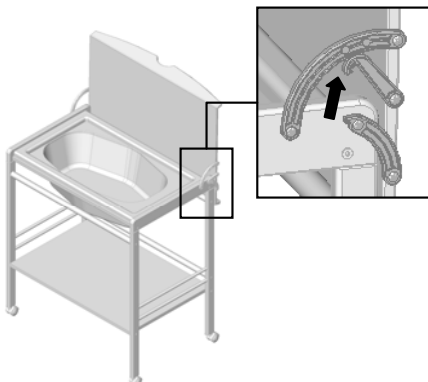
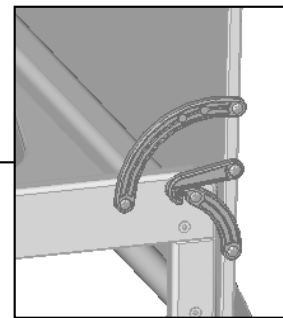
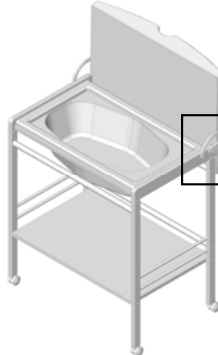
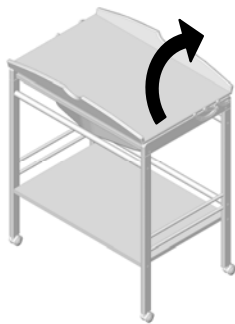

- (DE) Haken nach oben drücken bis er einrastet, nun Wickelplatte schließen.
Der Haken muss sich leichtgängig drehen.
- (GB) Push hook upward until it clicks into place. + The hook has to turn smoothly.
- (FR) Poussez le crochet vers le haut jusqu'à ce qu'il soit bien en place.
Le crochet doit pouvoir être tourné facilement.
- (NL) De haak naar boven drukken, tot hij vergrendelt. + De haak moet licht gangbaar draaien.
- (IT) Premere verso l'alto il gancio fino allo scatto in posizione.
Il gancio deve girarsi facilmente.
- (DK) Tryk krogen opad, til den går i indgreb. Krogen skal let lade sig dreje.
- (ES) Empujar el gancho hacia arriba hasta que encaje.
El gancho debe poder girarse con suavidad.
- (HU) A kampót nyomja fölfelé, amíg bepattan! + A kampónak könnyedén meg kell fordulnia.
- (FI) Paina koukkua ylöspäin kunnes se lukkiutuu paikalleen, sulje sitten hoitotasoa.
Koukun on kierryttävä helposti.
- (SI) Kljuko pritisniti navzgor dokler ne zaskoči, sedaj lahko previjalno ploščo zaprete.
Kljuka se mora z lahkoto obračati.
- (HR) Pritisnite kuku prema gore dok ne uskoči, a zatim zatvorite nakošenu ploču.
Kuka se mora lagano okretati.
- (NO) Kroken trykkes oppover inntil den smekker i, deretter kan du lukke stellebordet.
Kroken må kunne la seg dreie lett.
- (PL) Wcisnąć hak do góry do momentu zazębienia, a następnie zamknąć płytę do przewijania.
Hak musi się lekko obracać.
- (CZ) Háček stlačit směrem nahoru, až zaskočí, potom zavřít přebalovací desku.
Háček se musí snadno otáčet.
- (PT) Pressione o gancho para cima até engatar e feche a placa do fraldário.
O gancho deverá girar suavemente.
- (TR) Kancayı oturuncaya kadar yukarıya bastırınız, şimdi kundaklama levhasını kapatınız.
Kancanın kolay çevrilebilmesi gerekmektedir.
- (SK) Háč stlačte dohora, kým sa neupína, potom zatvorte prebaľovací dosku.
Háč musí mať ľahký beh.
- (SE) Tryck upp kroken tills den hakar fast och stäng sedan skötbordet.
Det måste gå lätt att vrida på kroken.
- (RS) Pritisnite kuku na gore tako da uskoči, a zatim zatvorite ploču za povijanje.
Kuka se mora lako okretati.
- (JP) フックをカチッとハマるまで上方に押し付けてから、オムツ交換台を閉じてください。
フックは軽く回転する状態でなくてはなりません。
- (CN) 钩子往上顶入卡槽，然后收起尿布更换台。钩子应能轻巧转动。
- (KR) 갈고리가 딱 끼워질 때까지 위로 눌러준 다음 지저귀 갈이대 판을 닫으십시오.
갈고리를 완만하고 가볍게 돌려줘야 합니다.

